

Heron Floor

with movable head

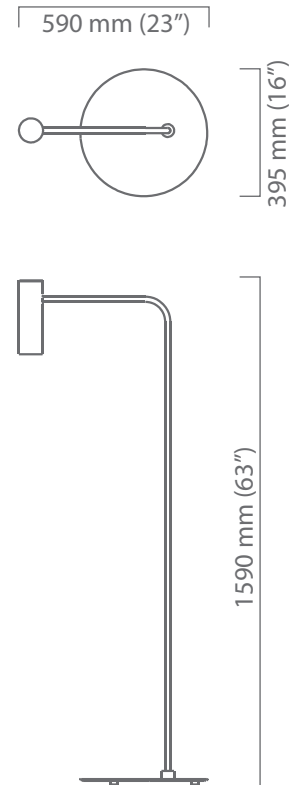

adjustable head position

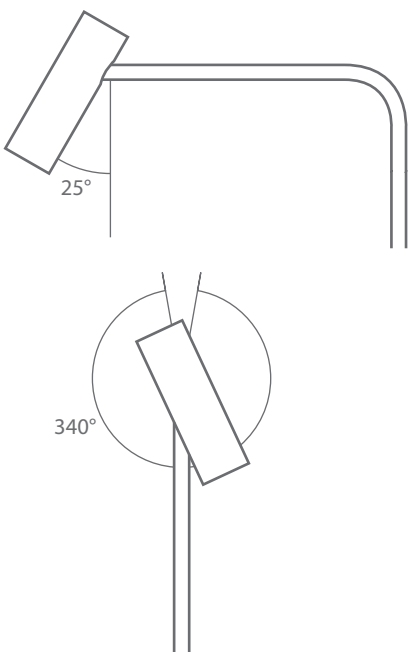

finish

satin brass

bulb holder

1 x GU10 retro-fit LED

wattage

1 x 5 watts

weight

15kg (33 lbs)

switch

in-line

designer

Michael Verheyden

certification

- our fittings are manufactured in accordance with EN 60598
- our fittings are not UL listed – please contact CTO Lighting /dealer should you require a fitting to be UL Listed